

# MP PRE 501 4R

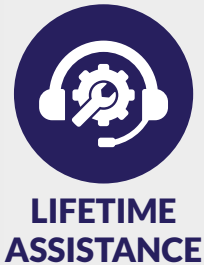
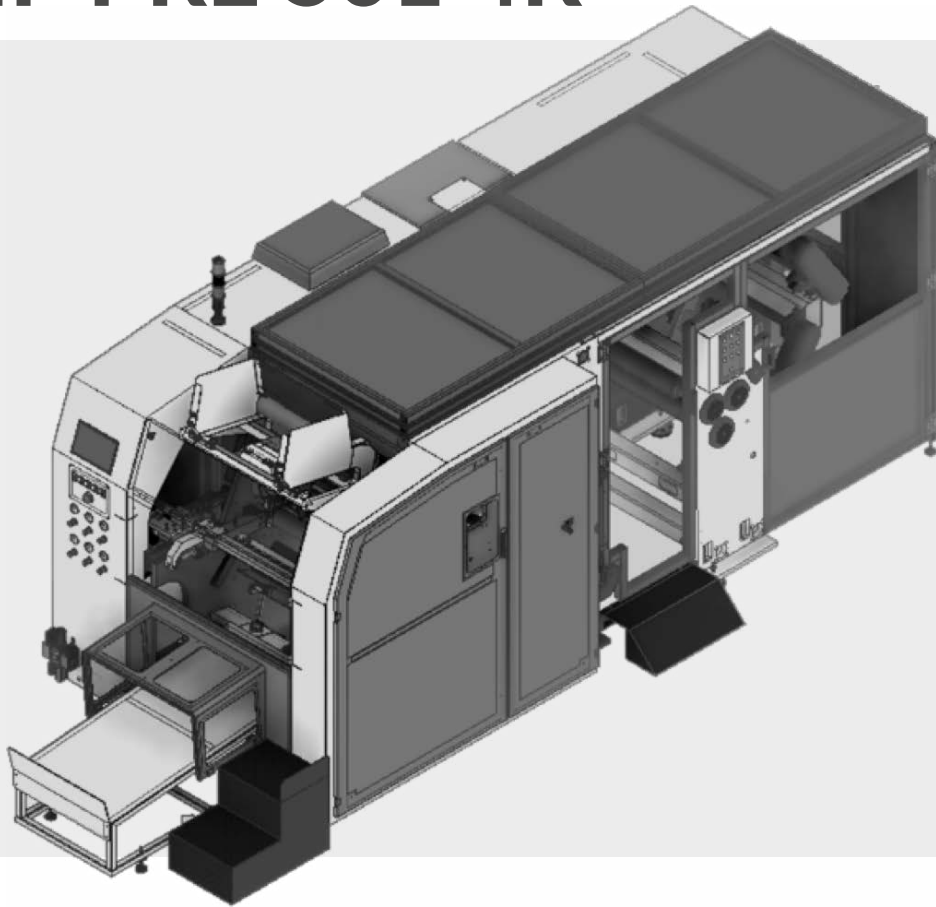

## TECHNICAL FEATURES

<b>Main Jumbo Roll</b>	500 mm (22") width
<b>Jumbo Roll Thickness</b>	10 to 23 $\mu$ m
<b>Jumbo Roll for reinforcement</b>	180 to 500 mm (7" to 22")
<b>Cardboard Cores Standard</b>	76 mm (3")
<b>Jumbo Roll loading by electric lift carriage</b>	
<b>Production speed</b>	macroperforated pre-stretched up to 500 m/min only pre-stretched up to 1000 m/min pre-stretched with reinforcement strips up to 1000 m/min
<b>Finished Roll Change System</b>	Shaftless with electrostatic charges
<b>Finished Roll</b>	Max Diameter 280 mm (11") Mandrels 38-50-76 mm (1,5 -"2-3") Perforation system (Patented) Winding tension Adjustable with automatic compensation Folding Edge Oscillating System Film adjustable in frequency and amplitude Diagnostic System new Visual Diagnostic and Teleassistance connection Operator Panel 10" Color touch screen Motors Brushless Motors and Vector Motors
<b>Air Supply</b>	8 bar (116 psi) 1000 NI/min
<b>Electric Supply</b>	3P 400/440 V, 50-60 Hz 38,5 kW (20 kW avg)
<b>Weight</b>	4200 Kg